

# CENTRAL PNEUMATIC 61489 OWNER'S MANUAL



## Quick Links

[Electrical](#)

[Features](#)

[Assembly](#)

[Operation](#)

[Maintenance](#)

[Maintenance](#)

[Troubleshooting](#)

## Table of Contents

[Table of Contents](#)

[Introduction](#)

[General Safety Rules](#)

[Specific Safety Rules](#)

[Symbols](#)

[Electrical](#)

[Glossary of Terms](#)

[Tools Needed](#)

[Features](#)

[Assembly](#)

[Operation](#)

[Operation](#)

[Maintenance](#)

[Maintenance](#)

[Troubleshooting](#)

[Troubleshooting](#)

[Warranty](#)

[Other ManualsLib Projects](#)

# Owner's Manual & Safety Instructions

**Save This Manual** Keep this manual for the safety warnings and precautions, assembly, operating, inspection, maintenance and cleaning procedures. Write the product's serial number in the back of the manual near the assembly diagram (or month and year of purchase if product has no number). Keep this manual and the receipt in a safe and dry place for future reference.

# CENTRALPNEUMATIC®

## 29<sup>GAL</sup> oil lubricated air compressor



Visit our website at: <http://www.harborfreight.com>  
Email our technical support at: [productsupport@harborfreight.com](mailto:productsupport@harborfreight.com)

**ITEM 61489**

When unpacking, make sure that the product is intact and undamaged. If any parts are missing or broken, please call 1-888-866-5797 as soon as possible.

### **⚠ WARNING**

**Read this material before using this product.  
Failure to do so can result in serious injury.  
SAVE THIS MANUAL.**

Copyright© 2013 by Harbor Freight Tools®. All rights reserved.

No portion of this manual or any artwork contained herein may be reproduced in any shape or form without the express written consent of Harbor Freight Tools. Diagrams within this manual may not be drawn proportionally. Due to continuing improvements, actual product may differ slightly from the product described herein. Tools required for assembly and service may not be included.



# IMPORTANT



## DO NOT RETURN TO STORE

This unit was fully tested and inspected prior to shipment and will operate properly when instructions are followed. Refer to your owner's manual for basic troubleshooting. **To avoid unnecessary return to the store, simply call Compressor Support toll free for additional assistance.**



**Compressor Support: 1-888-866-5797**

Please have your model number and serial number available. These can be found on the data label on your product. Retain a copy of your receipt with purchase date for reference.

### NOTICE

- Air Compressor will automatically shut off when maximum PSI is reached. When the tank pressure drops to the cut in pressure (low pressure) and the on/off switch is in the ON position, the unit will automatically restart.
- On occasion, maximum pressure in tank will remain until next use thus resulting in a sense of no power (See bullet above).
- To avoid power loss, overheating and ensure power, use additional air hose rather than extension cords.
- It is the consumer's responsibility to drain oil lubed units prior to shipment to meet ICC, state and local fire regulations.

## TABLE OF CONTENTS

- Introduction .....2
- General Safety Rules .....3-4
- Specific Safety Rules .....5
- Symbols.....6-7
- Electrical.....8
- Glossary of Terms .....9
- Tools Needed .....9
- Features .....10-11
- Assembly.....11-13
- Operation.....14-15
- Maintenance.....16-18
- Troubleshooting.....19-20
- Warranty .....22

## INTRODUCTION

This tool has many features for making its use more pleasant and enjoyable. Safety, performance, and dependability have been given top priority in the design of this product making it easy to maintain and operate.

### DANGER

This compressor/pump is not equipped and should not be used to supply breathing quality air. Additional equipment would be necessary to properly filter and purify the air to meet minimal specifications for Grade D breathing as described in Compressed Gas Association Commodity Specification G 7.1 - 1966, OSHA 29 CFR 1910.134. Compressed Gas Association, 4221 Walney Road, Fifth Floor, Chantilly, VA 20151-2923, (703) 788-2700, [www.cganet.com](http://www.cganet.com). Any such additional equipment has not been examined and no implication of proper use for breathing air is intended or implied.

If this compressor is altered in any way, existing warranties shall be voided. Harbor Freight Tools disclaims any liabilities whatsoever for any loss, personal injury, or damage.

# GENERAL SAFETY RULES



## WARNING:

Read and understand all instructions. Failure to follow all instructions listed below may result in electric shock, fire, and/or serious personal injury.

## SAVE THESE INSTRUCTIONS

### WORK AREA

- **Keep your work area clean and well lit.** Cluttered benches and dark areas invite accidents. The floor must not be slippery from wax or dust.
- **Do not operate power tools in explosive atmospheres, such as in the presence of flammable liquids, gases, or dust.** Power tools create sparks which may ignite the dust or fumes.
- **Keep bystanders, children, and visitors away while operating tools.** Distractions can cause you to lose control.
- **Operate the air compressor in an open area at least 18 in. away from any wall or object that could restrict the flow of fresh air to ventilation openings.**

### ELECTRICAL SAFETY

- **Avoid body contact with grounded surfaces such as pipes, radiators, ranges, and refrigerators.** There is an increased risk of electric shock if your body is grounded.
- **Don't expose power tools to rain or wet conditions.** Water entering a power tool will increase the risk of electric shock.
- **Do not abuse the cord. Never use the cord to carry the tool or pull the plug from an outlet. Keep the cord away from heat, oil, sharp edges, or moving parts. Replace damaged cords immediately.** Damaged cords increase the risk of electric shock.
- **When operating a power tool outside, use an outdoor extension cord marked "W-A" or "W".** These cords are rated for outdoor use and reduce the risk of electric shock.

### PERSONAL SAFETY

- **Eye protection which conforms to ANSI specifications and provides protection against flying particles both from the FRONT and SIDE should ALWAYS be worn by the operator and others in the work area when loading, operating, or servicing this tool.** Eye protection is required to guard against flying fasteners and debris, which could cause severe eye injury.
- **The employer and/or user must ensure that proper eye protection is worn.** We recommend a Wide Vision Safety Mask for use over eyeglasses or standard safety glasses that provide protection against flying particles both from the front and side. Always use eye protection which is marked to comply with ANSI Z87.1.

- **Additional safety protection will be required in some environments.** For example, the working area may include exposure to a noise level which can lead to hearing damage. The employer and user must ensure that any necessary hearing protection is provided and used by the operator and others in the work area. Some environments will require the use of head protection equipment. When required, the employer and user must ensure that head protection marked to comply with ANSI Z89.1 is used.
- **Stay alert, watch what you are doing, and use common sense when operating a power tool. Do not use tools while tired or under the influence of drugs, alcohol, or medication.** A moment of inattention while operating power tools may result in serious personal injury.
- **Dress properly. Do not wear loose clothing or jewelry. Contain long hair. Keep your hair, clothing, and gloves away from moving parts.** Loose clothes, jewelry, or long hair can be caught in moving parts.
- **Do not overreach. Keep proper footing and balance at all times.** Proper footing and balance enables better control of the tool in unexpected situations.
- **Use safety equipment. Always wear eye protection.** A dust mask, nonskid safety shoes, hard hat, or hearing protection must be used for appropriate conditions.
- **Do not use on a ladder or unstable support.** Stable footing on a solid surface enables better control of the tool in unexpected situations.

### TOOL USE AND CARE

- **Do not exceed the pressure rating of any component in the system.**
- **Protect material lines and air lines from damage or puncture.** Keep the hose and power cord away from sharp objects, chemical spills, oil, solvents, and wet floors.
- **Check hoses for weak or worn condition before each use, making certain all connections are secure.** Do not use if a defect is found. Purchase a new hose or notify an authorized service center for examination or repair.
- **Release the pressure within the system slowly.** Dust and debris may be harmful.
- **Store idle tools out of the reach of children and other untrained persons.** Tools are dangerous in the hands of untrained users.
- **Maintain tools with care.** Follow maintenance instructions. Properly maintained tools are easier to control.
- **Check for misalignment or binding of moving parts, breakage of parts, and any other condition that may affect the tool's operation. If damaged, have the tool serviced before using.** Many accidents are caused by poorly maintained tools.

# GENERAL SAFETY RULES

- **Never point any tool toward yourself or others.**
- **Keep the exterior of the air compressor dry, clean, and free from oil and grease.** Always use a clean cloth when cleaning. Never use brake fluids, gasoline, petroleum-based products, or any strong solvents to clean the unit. Following this rule will reduce the risk of deterioration of the enclosure plastic.
- **Disconnect the power supply, open the drain valve to decompress the tank and allow water to drain, and allow the air compressor to become cool to the touch before servicing.** Turn the pressure regulator knob fully counter clockwise after shutting off the compressor.
- **When servicing a tool, use only identical replacement parts. Follow the instructions in the Maintenance section of this manual.** Use of unauthorized parts or failure to follow the Maintenance instructions may create a risk of injury.

## SERVICE

- **Tool service must be performed only by qualified repair personnel.** Service or maintenance performed by unqualified personnel may result in a risk of injury.

# SPECIFIC SAFETY RULES

- **Know your power tool.** Read operator's manual carefully. Learn its applications and limitations, as well as the specific potential hazards related to this tool. Following this rule will reduce the risk of electric shock, fire, or serious injury.
- **Drain tank of moisture after each day's use.** If unit will not be used for a while, it is best to leave drain valve open until such time as it is to be used. This will allow moisture to completely drain out and help prevent corrosion on the inside of tank.
- **Risk of Fire or Explosion.** Do not spray flammable liquid in a confined area. Spray area must be well ventilated. Do not smoke while spraying or spray where spark or flame is present. Keep compressors as far from the spraying area as possible, at least 15 feet from the spraying area and all explosive vapors.
- **Risk of Bursting.** Do not adjust regulator to result in output pressure greater than marked maximum pressure of attachment. Do not use at pressure greater than the rated maximum pressure of this compressor.
- **If connected to a circuit protected by fuses,** use time-delay fuses with this product.
- **To reduce the risk of electric shock,** do not expose to rain. Store indoors.
- **Inspect tank yearly for rust, pin holes, or other imperfections that could cause it to become unsafe.** Never weld or drill holes in the air tank.
- **Make sure the hose is free of obstructions or snags.** Entangled or snarled hoses can cause loss of balance or footing and may become damaged.
- **Use the air compressor only for its intended use. Do not alter or modify the unit from the original design or function.**
- **Always be aware that misuse and improper handling of this tool can cause injury to yourself and others.**
- **Never leave a tool unattended with the air hose attached.**
- **Do not operate this tool if it does not contain a legible warning label.**
- **Do not continue to use a tool or hose that leaks air or does not function properly.**
- **Always disconnect the air supply and power supply before making adjustments, servicing a tool, or when a tool is not in use.**
- **Do not attempt to pull or carry the air compressor by the hose.**
- **Your tool may require more air consumption than this air compressor is capable of providing.**
- **Never use the compressor without guards (belt guard) and never touch moving parts.**
- **Always follow all safety rules recommended by the manufacturer of your tool, in addition to all safety rules for the air compressor.** Following this rule will reduce the risk of serious personal injury.
- **Never direct a jet of compressed air toward people or animals. Take care not to blow dust and dirt towards yourself or others.** Following this rule will reduce the risk of serious injury.
- **Protect your lungs.** Wear a face or dust mask if the operation is dusty. Following this rule will reduce the risk of serious personal injury.
- **Do not use this air compressor to spray chemicals.** Your lungs can be damaged by inhaling toxic fumes. A respirator may be necessary in dusty environments or when spraying paint. Do not carry while painting.
- **Inspect tool cords and hoses periodically and, if damaged, have repaired at your nearest Authorized Service Center. Constantly stay aware of cord location.** Following this rule will reduce the risk of electric shock or fire.
- **Never use an electrical adaptor with this grounded plug.**
- **Check damaged parts.** Before further use of the air compressor or air tool, a guard or other part that is damaged should be carefully checked to determine that it will operate properly and perform its intended function. Check for alignment of moving parts, binding of moving parts, breakage of parts, mounting, and any other conditions that may affect its operation. A guard or other part that is damaged should be properly repaired or replaced by an authorized service center. Following this rule will reduce the risk of shock, fire or serious injury.
- **Make sure your extension cord is in good condition.** When using an extension cord, be sure to use one heavy enough to carry the current your product will draw. A wire gauge size (A.W.G.) of at least 14 is recommended for an extension cord 50 feet or less in length. A cord exceeding 100 feet is not recommended. If in doubt, use the next heavier gauge. The smaller the gauge number, the heavier the cord. An undersized cord will cause a drop in line voltage resulting in loss of power and overheating.













## WARNING:

The brass components of this product contain lead, a chemical known to the state of California to cause birth defects (or other reproductive harm).  
(California health & safety code § 25249.5, et seq.)

- **Save these instructions.** Refer to them frequently and use them to instruct others who may use this air compressor. If you loan someone this tool, load them these instructions also.



# SYMBOLS

Some of the following symbols may be used on this tool. Please study them and learn their meaning. Proper interpretation of these symbols will allow you to operate the tool better and safer.

| SYMBOL  | NAME                       | DESIGNATION/EXPLANATION   |
|---|----------------------------|---|
| V   | Volts                      | Voltage   |
| A   | Amperes                    | Current   |
| Hz  | Hertz                      | Frequency (cycles per second)   |
| ~   | Alternating Current        | Type of current   |
|    | Class II Construction      | Double-insulated construction   |
|    | Wet Conditions Alert       | Do not expose to rain or use in damp locations.   |
|    | Read The Operator's Manual | To reduce the risk of injury, user must read and understand operator's manual before using this product.  |
|   | Eye Protection             | Always wear safety goggles, safety glasses with side shields, or a full face shield when operating this product.  |
|  | Safety Alert               | Precautions that involve your safety.   |
|  | Risk of Bursting           | Do not adjust regulator to result in output pressure greater than marked maximum pressure of attachment. Do not use at pressure greater than the rated maximum pressure of this compressor.   |
|  | Risk of Fire or Explosion  | Do not spray flammable liquid in a confined area. Spray area must be well ventilated. Do not smoke while spraying or spray where spark or flame is present. Keep compressors as far from the spraying area as possible, at least 15 feet from the spraying area and all explosive vapors. |
|  | Risk of Electrical Shock   | Hazardous Voltage: Disconnect from power source before servicing. Compressor must be grounded.  |
|  | Hot Surface                | To reduce the risk of injury or damage, avoid contact with any hot surface.   |
|  | Risk to hearing            | Always wear ear protection when using this tool. Failure to do so may result in hearing loss.   |
|  | Risk to Breathing          | Air obtained directly from the air compressor should never be used to supply air for human consumption.   |

# SYMBOLS

The following signal words and meanings are intended to explain the levels of risk associated with this product.

| SYMBOL  | SIGNAL          | MEANING  |
|---|-----------------|--|
|  | <b>DANGER:</b>  | Indicates an imminently hazardous situation, which, if not avoided, will result in death or serious injury.  |
|  | <b>WARNING:</b> | Indicates a potentially hazardous situation, which, if not avoided, could result in death or serious injury. |
|  | <b>CAUTION:</b> | Indicates a potentially hazardous situation, which, if not avoided, may result in minor or moderate injury.  |
|   | <b>CAUTION:</b> | (Without Safety Alert Symbol) Indicates a situation that may result in property damage.                      |

## SERVICE

Servicing requires extreme care and knowledge and should be performed only by a qualified service technician. For service we suggest you return the product to the nearest **AUTHORIZED SERVICE CENTER** for repair. When servicing, use only identical replacement parts.



### **WARNING:**

To avoid serious personal injury, do not attempt to use this product until you read thoroughly and understand completely the operator's manual. Save this operator's manual and review frequently for continuing safe operation and instructing others who may use this product.



### **WARNING:**



The operation of any power tool can result in foreign objects being thrown into your eyes, which can result in severe eye damage. Before beginning power tool operation, always wear safety goggles, safety glasses with side shields, or a full face shield when needed. We recommend Wide Vision Safety Mask for use over eyeglasses or standard safety glasses with side shields. Always use eye protection which is marked to comply with ANSI Z87.1.

## SAVE THESE INSTRUCTIONS

# ELECTRICAL

## EXTENSION CORDS

Use only 3-wire extension cords that have 3-prong grounding plugs and 3-pole receptacles that accept the air compressor's plug. When using the air compressor at a considerable distance from the power source, use an extension cord heavy enough to carry the current that the compressor will draw. An undersized extension cord will cause a drop in line voltage, resulting in a loss of power and causing the motor to overheat. Use the chart provided below to determine the minimum wire size required in an extension cord. Only round jacketed cords listed by Underwriter's Laboratories (UL) should be used.

\*\*Ampere rating (on air compressor data plate)

| Cord Length | Wire Size (A.W.G.) |         |         |         |          |           |
|-------------|--------------------|---------|---------|---------|----------|-----------|
|             | 0-2.0              | 2.1-3.4 | 3.5-5.0 | 5.1-7.0 | 7.1-12.0 | 12.1-16.0 |
| 25'         | 16                 | 16      | 16      | 16      | 14       | 14        |
| 50'         | 16                 | 16      | 16      | 14      | 14       | 12        |
| 100'        | 16                 | 16      | 14      | 12      | 10       | —         |

\*\*Used on 12 gauge - 20 amp circuit.

**NOTE:** AWG = American Wire Gauge

When working with the air compressor outdoors, use an extension cord that is designed for outside use. This is indicated by the letters "WA" on the cord's jacket.

Before using an extension cord, inspect it for loose or exposed wires and cut or worn insulation.

### **WARNING:**

Keep the extension cord clear of the working area. Position the cord so that it will not get caught on lumber, tools, or other obstructions while you are working with a power tool. Failure to do so can result in serious personal injury.

### **WARNING:**

Check extension cords before each use. If damaged, replace immediately. Never use air compressor with a damaged cord since touching the damaged area could cause electrical shock resulting in serious injury.

**NOTE:** Use longer air hoses instead of long extension cords. Your air compressor will run better and last longer.

## ELECTRICAL CONNECTION

This air compressor is powered by a precision built electric motor. It should be connected to a **power supply that is 120 volts, 60 Hz, AC only (normal household current)**. Do not operate this tool on direct current (DC). A substantial voltage drop will cause a loss of power and the motor will overheat. If the air compressor does not operate when plugged into an outlet, double check the power supply.

## SPEED AND WIRING

The no-load speed of the electric motor varies by model and specification. The motor speed is not constant and decreases under a load or with lower voltage. For voltage, the wiring in a shop is as important as the motor's horsepower rating. A line intended only for lights cannot properly carry a power tool motor. Wire that is heavy enough for a short distance will be too light for a greater distance. A line that can support one power tool may not be able to support two or three tools.

## GROUNDING INSTRUCTIONS

This product must be grounded. In the event of an electrical short circuit, grounding reduces the risk of electric shock by providing an escape wire for the electric current. This air compressor is equipped with an electric cord having an equipment-grounding conductor and a grounding plug. The plug must be plugged into a matching outlet that is properly installed and grounded in accordance with all local codes and ordinances.

Do not modify the plug provided. If it will not fit the outlet, have the proper outlet installed by a qualified electrician.



### **WARNING:**

Improper connection of the equipment-grounding conductor can result in a risk of electric shock.

The conductor with insulation having an outer surface that is green with or without yellow stripes is the equipment-grounding conductor. If repair or replacement of the electric cord or plug is necessary, do not connect the equipment-grounding conductor to a live terminal.

Check with a qualified electrician or service personnel if the grounding instructions are not completely understood, or if in doubt as to whether the tool is properly grounded.

Repair or replace a damaged or worn cord immediately.

This product is for use on a nominal 120-V circuit and has a grounding plug similar to the plug illustrated in Figure 1. Only connect the product to an outlet having the same configuration as the plug. Do not use an adapter with this product.

**Never use an electrical adaptor with this grounded plug.**

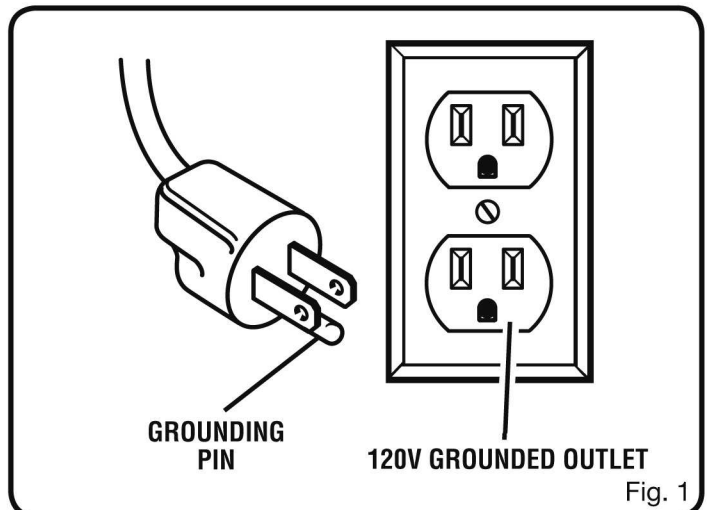

# GLOSSARY OF TERMS

## **Air Filter**

Porous element contained within a metal or plastic housing attached to the compressor cylinder head which removes impurity from the intake air of the compressor.

## **Air Tank**

Cylindrical component which contains the compressed air.

## **Check Valve**

Device that prevents compressed air from flowing back from the air tank to the compressor pump.

## **Cut-In Pressure**

The low pressure at which the motor will automatically restart.

## **Cut-Off Pressure**

The high pressure at which the motor will automatically shut off.

## **Electric Motor**

Device which provides the rotational force necessary to operate the compressor pump.

## **Manual On/Off Switch**

Control which turns the air compressor on or off. The pressure switch will not automatically start and control the compressor unless the manual On/Off Switch is in the **ON (I)** position.

## **NPT (National Pipe Thread)**

National Pipe Thread is a U.S. standard for tapered (NPT) or straight (NPS) threads used to join pipes and fittings. A thread sealing tape must be used to provide a leak-free seal on pipe threaded connections.

## **Pressure Regulator Knob**

Regulates the outgoing pressure from the air outlet to the tool. It is possible to increase or decrease the pressure at the outlet by adjusting this control knob.

## **Pressure Switch**

Automatically controls the on/off cycling of the compressor. It stops the compressor when the cut-off pressure in the tank is reached and starts the compressor when the air pressure drops below the cut-in pressure.

## **PSI (Pounds Per Square Inch)**

Measurement of the pressure exerted by the force of the air. The actual psi is measured by a pressure gauge on the compressor.

## **Pump**

Produces the compressed air with a reciprocating piston contained within the cylinder.

## **Regulator Pressure Gauge**

Displays the current line pressure. Line pressure is adjusted by rotating the pressure regulator knob.

## **Safety Valve**

Prevents air pressure in the air tank from rising over a predetermined limit.

## **SCFM (Standard Cubic Feet Per Minute)**

A unit of measure of air delivery.

## **Tank Pressure Gauge**

Indicates the pressure in the air tank.

## **Thermal Overload Switch**

Automatically shuts off the compressor if the temperature of the electric motor exceeds a predetermined limit.

# TOOLS NEEDED

The following tools are needed in order to assemble the wheel kit.

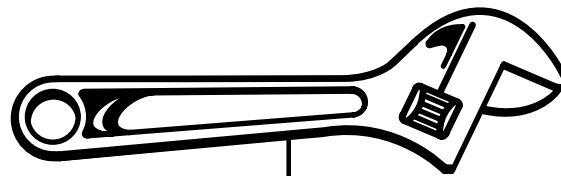

**TWO ADJUSTABLE WRENCHES**

# FEATURES

## PRODUCT SPECIFICATIONS

Running Horsepower..... 2 HP  
 Air Tank Capacity..... 29 gal.  
 Air Pressure..... 150 PSI max.  
 Air Delivery ..... 7.5 SCFM @ 40 PSI  
 ..... 6.4 SCFM @ 90 PSI

Lubrication.....Oil  
 Gauges..... 2.0 in. diameter  
 Input..... 120 V, 60 Hz, AC only, 15 Amps  
 Net Weight.....169.8 lbs.

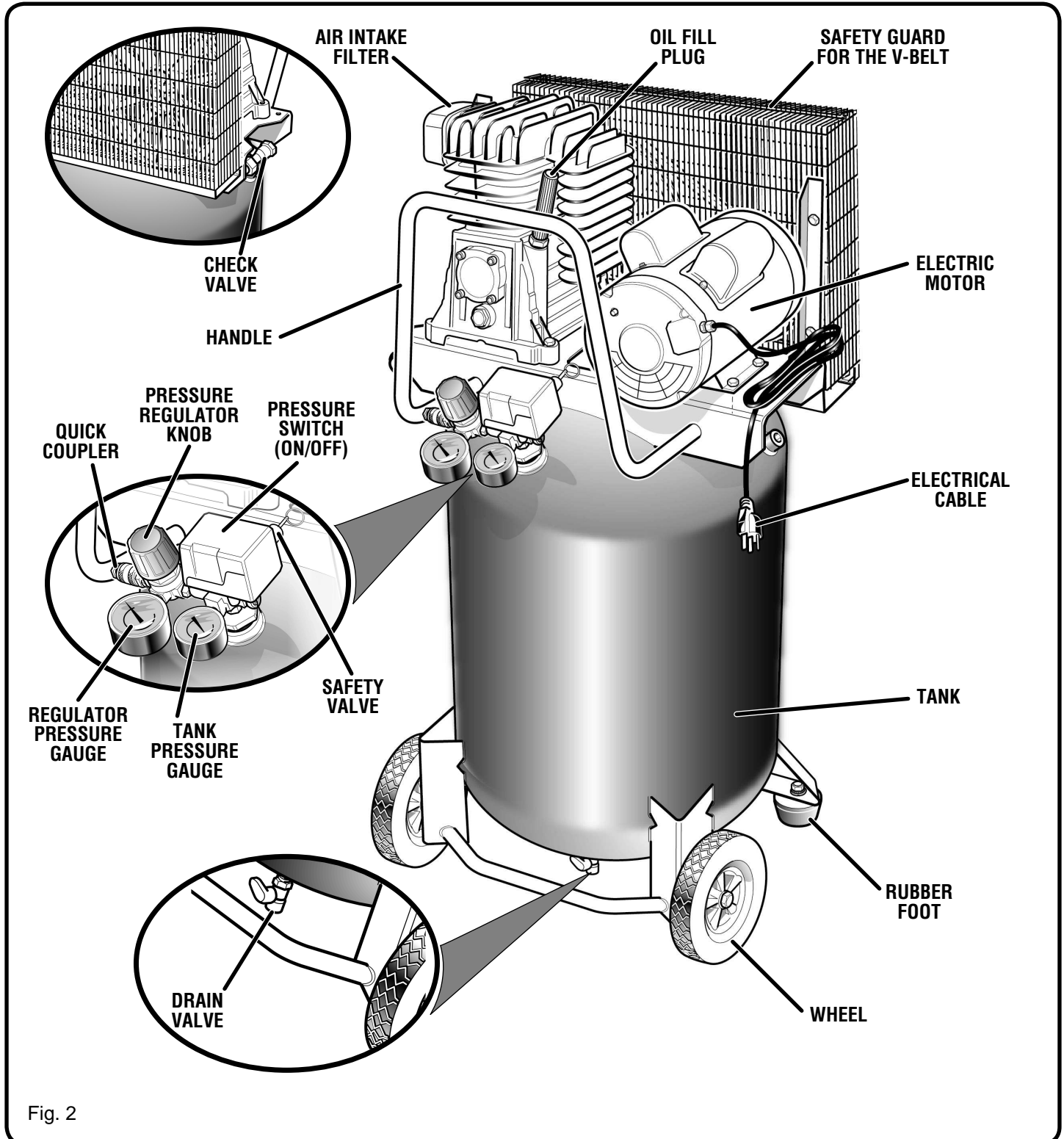

# FEATURES

## KNOW YOUR AIR COMPRESSOR

See Figure 2.

Before attempting to use this product, familiarize yourself with all operating features and safety rules.

## DESCRIPTION

Your air compressor is aircooled, oil lubricated, belt-driven, single stage.

## PRESSURE REGULATOR KNOB

Use the pressure regulator knob to adjust the amount of air being delivered through the hose.

## REGULATOR PRESSURE GAUGE

The current line pressure is displayed on the regulator pressure gauge. This pressure can be adjusted by rotating the pressure regulator knob.

## SAFETY VALVE

The safety valve is designed to automatically release air if the air receiver pressure exceeds the preset maximum.

## CHECK VALVE

Check valves are designed to allow air to flow freely in one direction only.

## TANK PRESSURE GAUGE

The tank pressure gauge indicates the pressure of the air in the tank.

# ASSEMBLY

## UNPACKING

This product has been shipped completely assembled, except the two rubber feet and the two wheels.

- Carefully remove the compressor from the box. Make sure that all items listed in the packing list are included.
- Inspect the compressor carefully to make sure no breakage or damage occurred during shipping.
- Do not discard the packing material until you have carefully inspected and satisfactorily operated the tool.
- If any parts are damaged or missing, please call 1-888-866-5797 for assistance.

## PACKING LIST

Air Compressor (1)  
Operator's Manual (1)  
Replacement Parts List (1)

### WARNING:

If any parts are missing do not operate the compressor or air tools until the missing parts are replaced. Failure to do so could result in possible serious personal injury.

### WARNING:

Do not attempt to modify this tool or create accessories not recommended for use with this tool. Any such alteration or modification is misuse and could result in a hazardous condition leading to possible serious personal injury.

# ASSEMBLY

## ASSEMBLING THE RUBBER FOOT AND WHEELS

See Figure 3.

- Mount the rubber feet as shown in figure. Tighten firmly with an open-end wrench (not included) to secure it in position.
- Mount the wheels as shown in figure. Tighten firmly with an open-end wrench (not included) to secure the wheels in position.

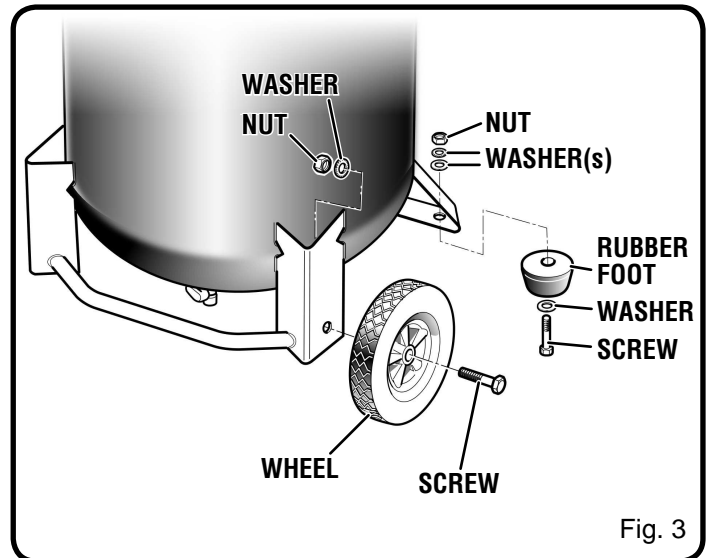

# ASSEMBLY

## BREAKING IN THE PUMP

See Figures 4 - 7.

- Check and tighten all bolts, fittings, etc.
- Turn the pressure regulator knob fully clockwise to open the air flow.
- Place the lever of the pressure switch in 'OFF' position and plug in the power cord.
- Open the drain valve completely.
- Place the lever of the pressure switch in 'AUTO' position and run the air compressor for 10 minutes to break in pump parts.
- Place the lever of the pressure switch in 'OFF' position.
- Close the drain valve.

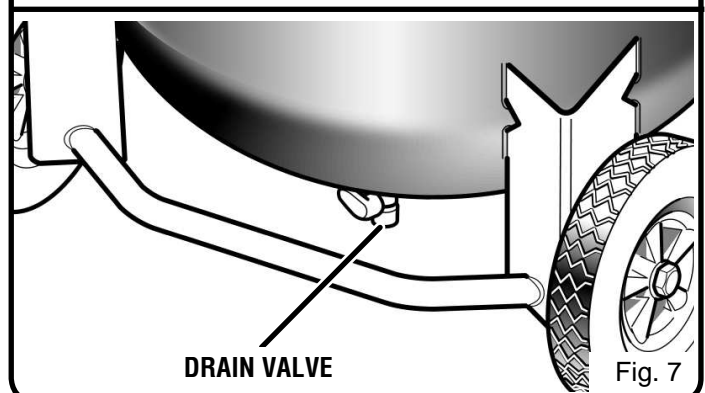
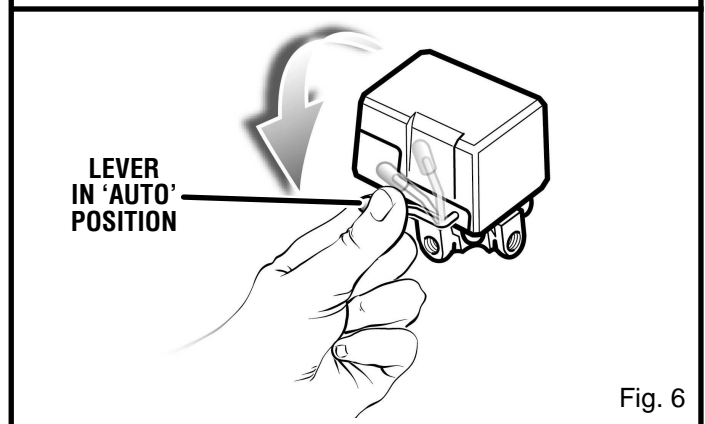
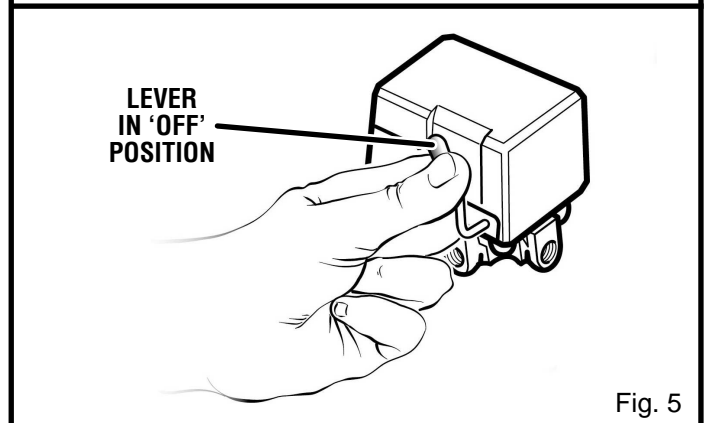
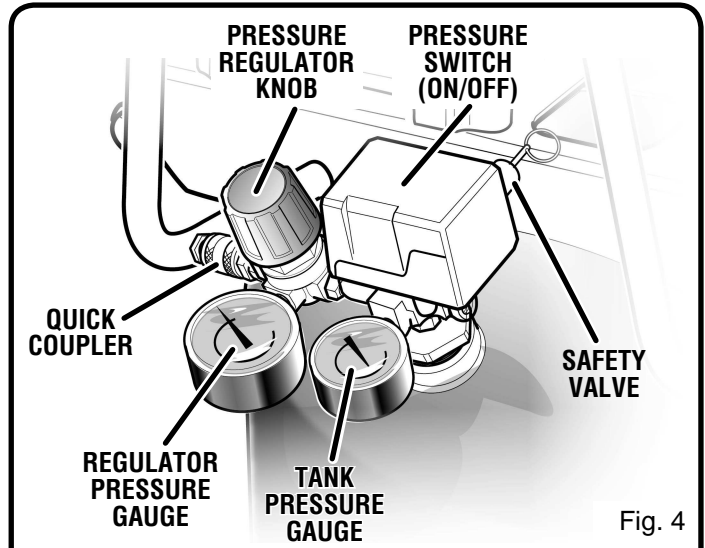

# OPERATION

## **WARNING:**

Do not allow familiarity with tools to make you careless. Remember that a careless fraction of a second is sufficient to inflict serious injury.

## **WARNING:**

Always wear safety goggles or safety glasses with side shields when operating power tools. Failure to do so could result in objects being thrown into your eyes resulting in possible serious injury.

## **CAUTION:**

Do not use in an environment that is dusty or otherwise contaminated. Using the air compressor in this type of environment may cause damage to the unit.

## APPLICATIONS

Air compressors are utilized in a variety of air system applications. Match hoses, connectors, air tools, and accessories to the capabilities of the air compressor.

You may use this tool for purposes listed below:

- Operating some air-powered tools.
- Inflating tires, air beds, sports equipment, etc.

## USING THE AIR COMPRESSOR

See Figures 4 - 6.

- Ensure tank drain is closed.
- Ensure lever of the pressure switch is in the 'OFF' position and air compressor is unplugged.
- Connect the air line to the quick coupler.

## **WARNING:**

Always ensure the lever of the pressure switch is in the 'OFF' position and the regulator pressure gauge read zero before changing air tools or disconnecting the hose from the air outlet. Failure to do so could result in possible serious personal injury.

- Rotate regulator knob fully counterclockwise in order to close the air flow.
- Fill the compressor pump with oil. Do not overfill.
- Connect the power cord to the power supply.
- Place the lever of the pressure switch in 'AUTO' position, in order to switch on the compressor.
- Rotate pressure regulator knob to desired line pressure. Turning the knob clockwise increases air pressure at the outlet; turning counterclockwise reduces air pressure at the outlet.

## **WARNING:**

Your tool may require more air consumption than this air compressor is capable of providing. Check the tool manual to avoid damage to the tool or risk of personal injury.

- Following all safety precautions in this manual and the manufacturer's instructions in the air tool manual, you may now proceed to use your air-powered tool.
- If using an inflation accessory, control the amount of air flow with the pressure regulator knob. Turning the knob fully counterclockwise will completely stop the flow of air.  
**NOTE:** Always use the minimum amount of pressure necessary for your application. Using a higher pressure than needed will drain air from the tank more rapidly and cause the unit to cycle on more frequently.
- When finished, always drain the tank and unplug the unit. Never leave the unit plugged in and/or running unattended.

# OPERATION

## DRAINING THE TANK

See Figures 8 - 9.

To help prevent tank corrosion and keep moisture out of the air used, the tank of the compressor should be drained daily.

### A correct use of the drain valve:

- Verify that the compressor is turned off.
- Holding the handle, tilt the compressor toward the drain valve so that it's set in a lower position.
- Open the drain valve completely.
- Keep the compressor tilted (figure 9) until all moisture has been removed.
- Drain moisture from tank into a suitable container.  
**NOTE:** Condensate is a polluting material and should be disposed of in compliance with local regulations.
- If drain valve is clogged, release all air pressure by pulling the safety valve. Remove and clean valve, then reinstall.

### WARNING:

Unplug the air compressor and release all air from the tank before servicing. Failure to depressurize tank before attempting to remove valve may cause serious personal injury.

- Turn off drain valve until completely closed.

## CHECKING THE SAFETY VALVE

See Figure 10.

### WARNING:

Do not attempt to tamper with safety valve. Anything loosened from this device could fly up and hit you. Failure to heed this warning could result in death or serious personal injury.

The safety valve will automatically release air if the air receiver pressure exceeds the preset maximum. The valve should be checked before each day of use by pulling the ring by hand.

- Turn the air compressor on and allow the tank to fill. The compressor will shut off when the pressure reaches the preset maximum.
- Turn the air compressor off.
- Pull the ring on the safety valve to release air for twenty seconds.
- Release the ring. Air must immediately stop escaping when the ring is released. Any continued loss of air after releasing the safety valve ring indicates a problem with the safety valve. Discontinue use and seek service before continued use of the air compressor.

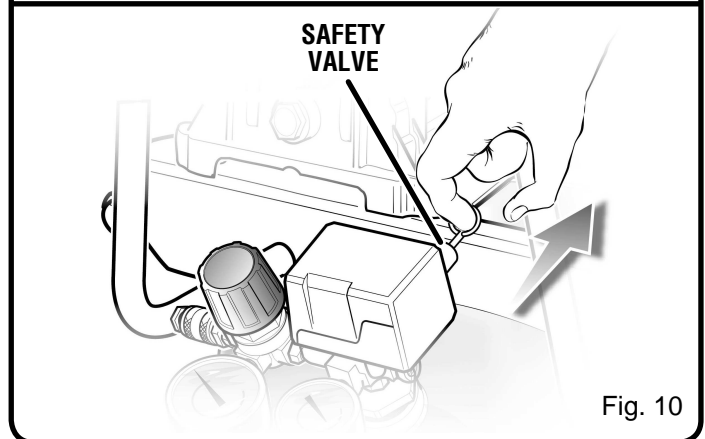
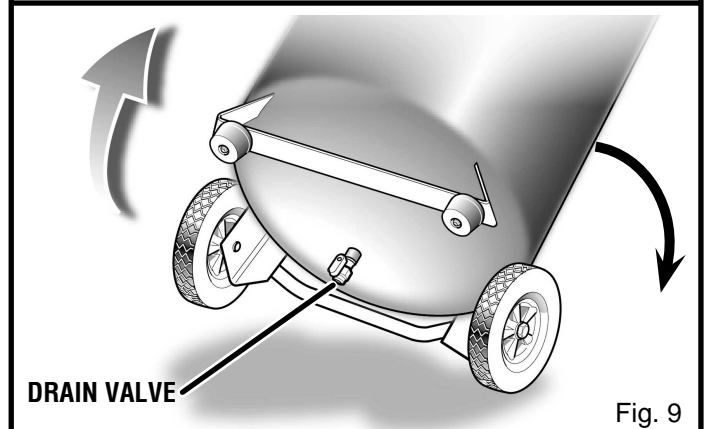
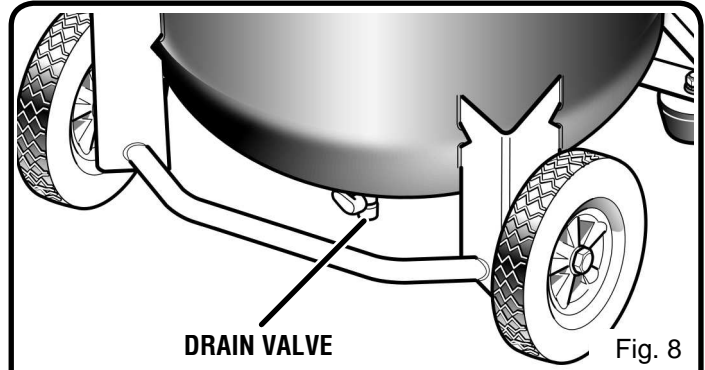

### WARNING:

If air leaks after the ring has been released, or if the valve is stuck and cannot be actuated by the ring, Do Not use the air compressor until the safety valve has been replaced. Use of the air compressor in this condition could result in serious personal injury.

# MAINTENANCE

## **⚠ WARNING:**

When servicing, use only identical Harbor Freight Tools replacement parts. Use of any other parts may create a hazard or cause product damage.

## **⚠ WARNING:**

Always wear safety goggles or safety glasses with side shields during power tool operation or when blowing dust. If operation is dusty, also wear a dust mask.

## **⚠ WARNING:**

Always release all pressure, disconnect from power supply, and allow unit to cool to the touch before cleaning or making repairs on the air compressor.

## GENERAL MAINTENANCE

Humidity in the air causes condensate to form in the air tank. This condensate should be drained daily and/or every hour, using the instructions found in **Draining the Tank**.

The safety valve automatically releases air if the air receiver pressure exceeds the preset maximum. Check the safety valve before each use following the instructions found in **Checking the Safety Valve**.

Inspect the tank yearly for rust, pin holes, or other imperfections that could cause it to become unsafe.

Avoid using solvents when cleaning plastic parts. Most plastics are susceptible to damage from various types of commercial solvents and may be damaged by their use. Use clean cloths to remove dirt, dust, oil, grease, etc.

## **⚠ WARNING:**

Do not at any time let brake fluids, gasoline, petroleum-based products, penetrating oils, etc., come in contact with plastic parts. Chemical can damage, weaken or destroy plastic which may result in serious personal injury. Electric tools used on fiberglass material, wall-board, spackling compounds, or plaster are subject to accelerated wear and possible premature failure because the fiberglass chips and grindings are highly abrasive to bearings, brushes, commutators, etc. Consequently, we do not recommend using this tool for extended work on these type of materials. However, if you do work with any of these materials, it is extremely important to clean the tool using compressed air.

## CHECK THE OIL LEVEL AT REGULAR INTERVALS

See Figure 11.

Place the compressor on a level and straight surface. The oil level must be between the two marks MAX and MIN on the oil sight glass (fig. 11).

**Changing the oil:** use SAE 40 oil (for cold climates, SAE 20 is recommended). Do not mix different grade oils. If the oil changes color (whitish = presence of water; dark = overheated), it is good practice to replace the oil immediately.

It should be refilled for the first time after 100 hours of operation. Thereafter the oil should be drained and refilled after every 300 hours in service.

## CHANGING THE OIL

See Figures 11 - 12.

Switch off the engine and pull the mains plug out of the socket. After releasing any air pressure you can unscrew the oil drain plug (fig. 11) from the compressor pump. To prevent the oil from running out in an uncontrolled manner, hold a small metal chute under the opening and collect the oil in a vessel. If the oil does not drain out completely, we recommend tilting the compressor slightly.

Dispose of the old oil at a drop-off point for old oil.

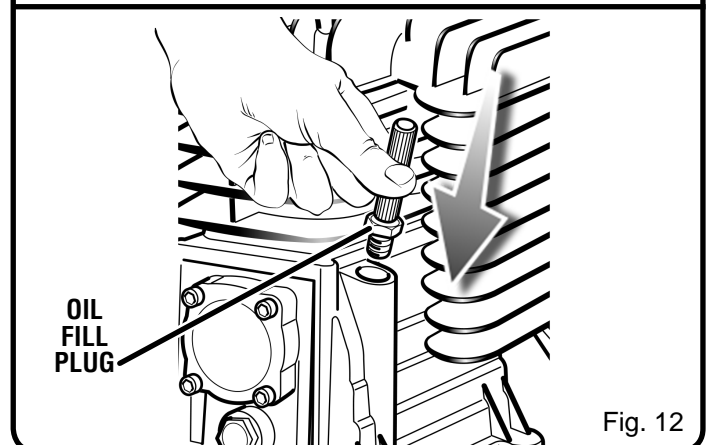
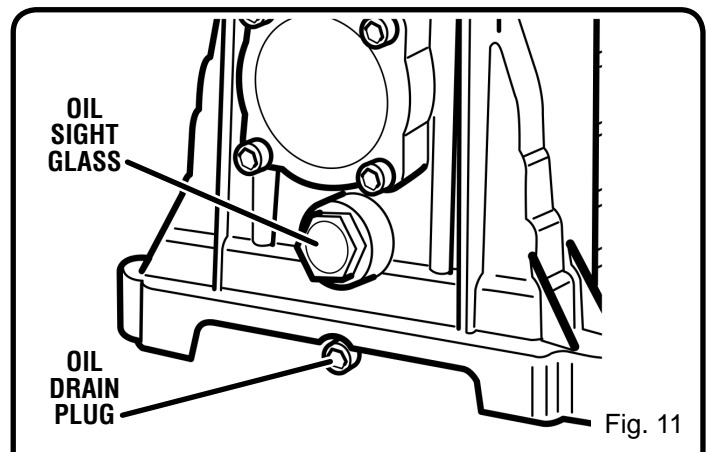

# MAINTENANCE

When the oil has drained out, re-fit the oil drain plug (fig. 11). Fill new oil through the oil filler opening until it comes up to the required level. Do not overfill. After topping up, tighten the oil fill plug (fig. 12), making sure that there are no leaks during use. Once a week, check the oil level to assure proper lubrication.

## RETENSIONING THE V-BELT

See Figures 13 - 15.

- Pull out the power plug and remove the safety guard for the V-belt (figures 13 - 14).
- Slacken the four motor fixing screws (figure 15).
- Shift the motor until the V-belt is tensioned to the point where it can still be depressed by approx. 0.4-0.8 in. (1-2 cm) at the longest free position.
- Retighten the motor fixing screws and refit the safety guard for the V-belt.

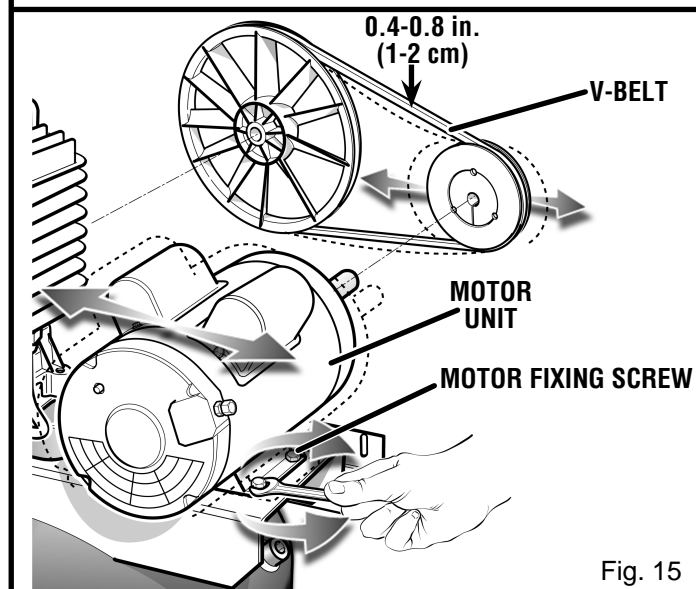
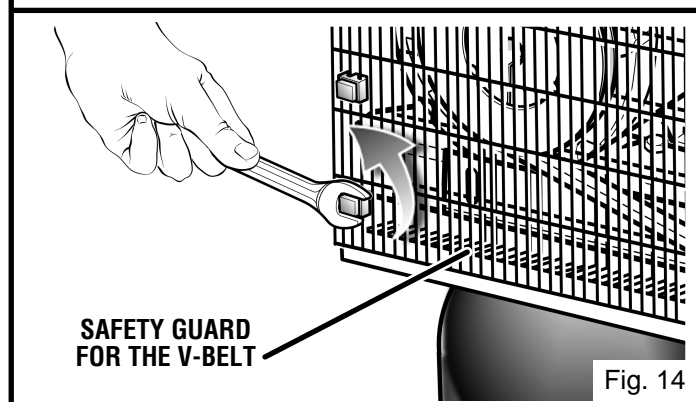
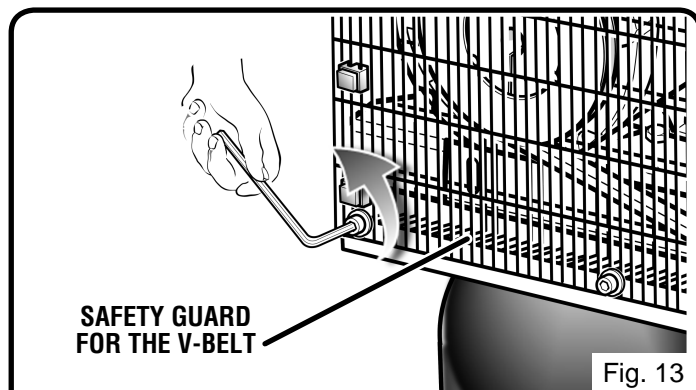

## TIGHTENING OF HEAD TENSION RODS

See Figure 16.

- Check that all screws (in particular those of the head of the unit) are tightly drawn up.
- The check must be carried out prior to the first compressor starting. And after the first hour of work.
- Tightening values for the tension rods of the head:
  - Nm min. torque = 22**
  - Nm max. torque = 27**

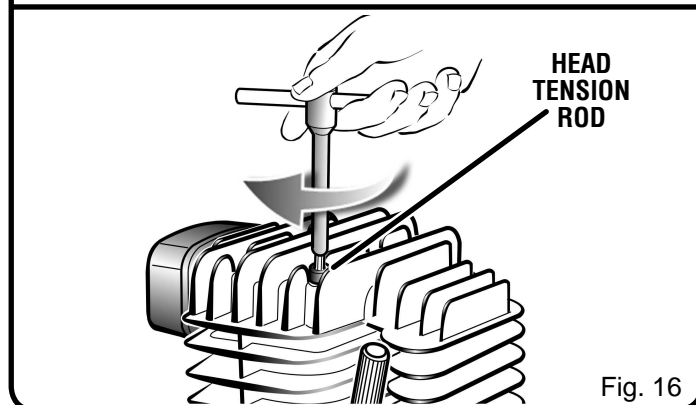

# MAINTENANCE

## CLEANING THE INTAKE FILTER

See Figure 17.

The intake filter prevents dust and dirt being drawn in. It is essential to clean this filter after at least every 100 hours in service. A clogged intake filter will decrease the compressor's performance dramatically. Undo the two allen screws. You can then remove the filter from the two halves of the plastic housing, tap it to remove the dirt, blast it down with low-pressure compressed air (approx. 3 bar) and re-insert it.

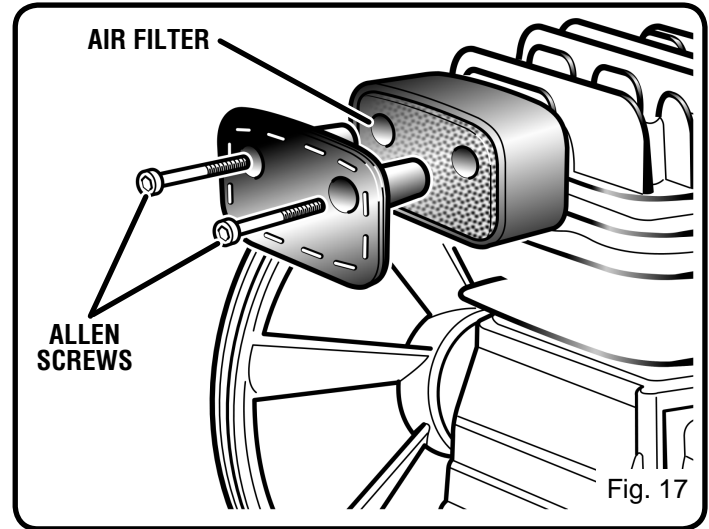

# TROUBLESHOOTING

| Problem   | Possible Cause   | Solution   |
|---|--|--|
| Compressor will not run                               | Loss of power or overheating<br><br>No electrical power<br><br>Blown shop/house fuse<br>Shop/house breaker open<br><br>Thermal overload open<br>Pressure switch bad<br>Tank is full of air | Check for proper use of extension cord<br><br>Check to be sure unit is plugged in<br>Check fuse/breaker or motor overload<br><br>Replace shop/house blown fuse<br>Reset shop/house breaker, determining why problem happened<br>Motor will restart when cool<br>Replace pressure switch<br>Compressor will turn on when tank pressure drops to cut-in pressure |
| Motor hums but cannot run or runs slowly              | Low voltage<br>Wrong gauge wire or length of extension cord<br>Shorted or open motor winding<br>Defective check valve or unloader  | Check with voltmeter<br>Check for proper gauge wire and cord length<br>Take compressor to service center<br>Take compressor to service center  |
| Fuses blow/circuit breaker trips repeatedly           | Incorrect size fuse, circuit overload<br><br>Wrong gauge wire or length of extension cord<br>Defective check valve or under loader   | Check for proper fuse, use time-delay fuse, disconnect other electrical appliances from circuit or operate compressor on its own branch circuit<br>Check for proper gauge wire and cord length<br>Take compressor to service center  |
| Thermal overload protector cuts out repeatedly        | Low voltage<br>Lack of proper ventilation/room temperature too high<br>Wrong gauge wire or length of extension cord  | Check with voltmeter<br>Move compressor to well-ventilated area<br>Check for proper gauge wire and cord length   |
| Air receiver pressure drops when compressor shuts off | Loose connections (fittings, tubing, etc.)<br>Loose drain valve<br>Check valve leaking   | Check all connections with soap and water solution and tighten<br>Tighten drain valve<br>Take compressor to service center<br><br><div style="border: 1px solid black; padding: 5px; margin-top: 10px;"> <p><b>⚠ DANGER:</b><br/>Do not disassemble check valve with air in tank — bleed tank.</p> </div>  |
| Excessive moisture in discharge air                   | Excessive water in air tank<br>High humidity   | Drain tank<br>Move to area of less humidity; use air line filter   |
| Compressor runs continuously                          | Defective pressure switch<br>Excessive air usage   | Take compressor to service center<br>Decrease air usage; compressor not large enough for tool's requirement  |
| Compressor vibrates                                   | Loose mounting bolts   | Tighten mounting bolts   |
| Air output lower than normal                          | Broken inlet valves<br>Connections leaking   | Take compressor to service center<br>Tighten connections   |

# TROUBLESHOOTING

| Problem   | Possible Cause   | Solution  |
|---|--|---|
| Air leak from the valve of the pressure switch  | <p>Check valve does not perform its function correctly due to wear or dirt on the seal</p> <p>Condensate drainage cock open</p> <p>Rilsan hose not inserted correctly in pressure switch</p> | <p>Unscrew the hex-shaped head of the check valve, clean the housing and the special rubber disk (replace if worn). Re-assembler and tighten carefully</p> <p>Close the condensate drainage cock</p> <p>Insert the Rilsan hose correctly inside the pressure switch</p>   |
| Reduction of efficiency, frequent start-up. Low pressure values   | <p>Excessively high consumption</p> <p>Leaks from joints and/or pipes</p> <p>Clogging of the suction filter</p> <p>Slipping of the belt</p>  | <p>Decrease the demand of compressed air</p> <p>Change gaskets</p> <p>Clean/replace the suction filter</p> <p>Check V-belt tension</p>  |
| The motor and/or the compressor overheat irregularly  | <p>Insufficient ventilation</p> <p>Closing of air ducts</p> <p>Insufficient lubrication</p>  | <p>Improve ambient conditions</p> <p>Check and if necessary clean the air filter</p> <p>Top up or change oil</p>  |
| After an attempt to start the compressor, it stops due to tripping of the thermal cutout caused by forcing of the motor   | <p>Start-up with head of the compressor charged</p> <p>Low temperature</p> <p>Voltage too low</p> <p>Incorrect or insufficient lubrication</p> <p>Inefficient electrovalve</p>               | <p>Release the compressor head by using the pressure switch push button</p> <p>Improve ambient conditions</p> <p>Check that the mains voltage matches that of the dataplate. Eliminate any extensions</p> <p>Check level, top up and if necessary change the oil</p> <p>Take compressor to the service center</p> |
| During operation, the compressor stops for no apparent reason   | <p>Tripping of the thermal cutout of the motor</p> <p>Electric fault</p>   | <p>Check level oil</p> <p>Operate on the lever of the pressure switch returning this to the OFF position.</p> <p>Reset the thermal cutout and restart.</p> <p>If the fault persists, take the compressor to the service center</p> <p>Take compressor to the service center</p>                                   |
| When operating, the compressor vibrates and the motor emits an irregular buzzing sound. If it stops, it does not restart although the sound of the motor is present | Faulty capacitor   | Have the capacitor replaced   |
| Irregular presence of oil in the network  | <p>Too much oil inside the unit</p> <p>Wear on segments</p>  | <p>Check oil level</p> <p>Take compressor to the service center</p>   |
| Leaking of condensate from the vent cock  | Presence of dirt/grit inside the cock  | Clean the cock  |



## Limited 90 Day Warranty

Harbor Freight Tools Co. makes every effort to assure that its products meet high quality and durability standards, and warrants to the original purchaser that this product is free from defects in materials and workmanship for the period of 90 days from the date of purchase. This warranty does not apply to damage due directly or indirectly, to misuse, abuse, negligence or accidents, repairs or alterations outside our facilities, criminal activity, improper installation, normal wear and tear, or to lack of maintenance. We shall in no event be liable for death, injuries to persons or property, or for incidental, contingent, special or consequential damages arising from the use of our product. Some states do not allow the exclusion or limitation of incidental or consequential damages, so the above limitation of exclusion may not apply to you. THIS WARRANTY IS EXPRESSLY IN LIEU OF ALL OTHER WARRANTIES, EXPRESS OR IMPLIED, INCLUDING THE WARRANTIES OF MERCHANTABILITY AND FITNESS.

To take advantage of this warranty, the product or part must be returned to us with transportation charges prepaid. Proof of purchase date and an explanation of the complaint must accompany the merchandise. If our inspection verifies the defect, we will either repair or replace the product at our election or we may elect to refund the purchase price if we cannot readily and quickly provide you with a replacement. We will return repaired products at our expense, but if we determine there is no defect, or that the defect resulted from causes not within the scope of our warranty, then you must bear the cost of returning the product.

This warranty gives you specific legal rights and you may also have other rights which vary from state to state.



### **WARNING:**

The brass components of this product contain lead, a chemical known to the state of California to cause birth defects (or other reproductive harm).  
(California health & safety code § 25249.5, et seq.)

**3491 Mission Oaks Blvd. • PO Box 6009 • Camarillo, CA 93011 • 1-888-866-5797**

# CENTRALPNEUMATIC®

## Portable Air Compressor Model No. 61489 Replacement Parts List

**Record Serial Number Here:** \_\_\_\_\_

**Note:** If product has no serial number, record month and year of purchase instead.

**Note:** Some parts are listed and shown for illustration purposes only, and are not available individually as replacement parts.

### PLEASE READ THE FOLLOWING CAREFULLY

---

THE MANUFACTURER AND/OR DISTRIBUTOR HAS PROVIDED THE PARTS LIST AND ASSEMBLY DIAGRAM AS A REFERENCE TOOL ONLY. NEITHER THE MANUFACTURER OR DISTRIBUTOR MAKES ANY REPRESENTATION OR WARRANTY OF ANY KIND TO THE BUYER THAT HE OR SHE IS QUALIFIED TO MAKE ANY REPAIRS TO THE PRODUCT, OR THAT HE OR SHE IS QUALIFIED TO REPLACE ANY PARTS OF THE PRODUCT. IN FACT, THE MANUFACTURER AND/OR DISTRIBUTOR EXPRESSLY STATES THAT ALL REPAIRS AND PARTS REPLACEMENTS SHOULD BE UNDERTAKEN BY CERTIFIED AND LICENSED TECHNICIANS, AND NOT BY THE BUYER. THE BUYER ASSUMES ALL RISK AND LIABILITY ARISING OUT OF HIS OR HER REPAIRS TO THE ORIGINAL PRODUCT OR REPLACEMENT PARTS THERETO, OR ARISING OUT OF HIS OR HER INSTALLATION OF REPLACEMENT PARTS THERETO.

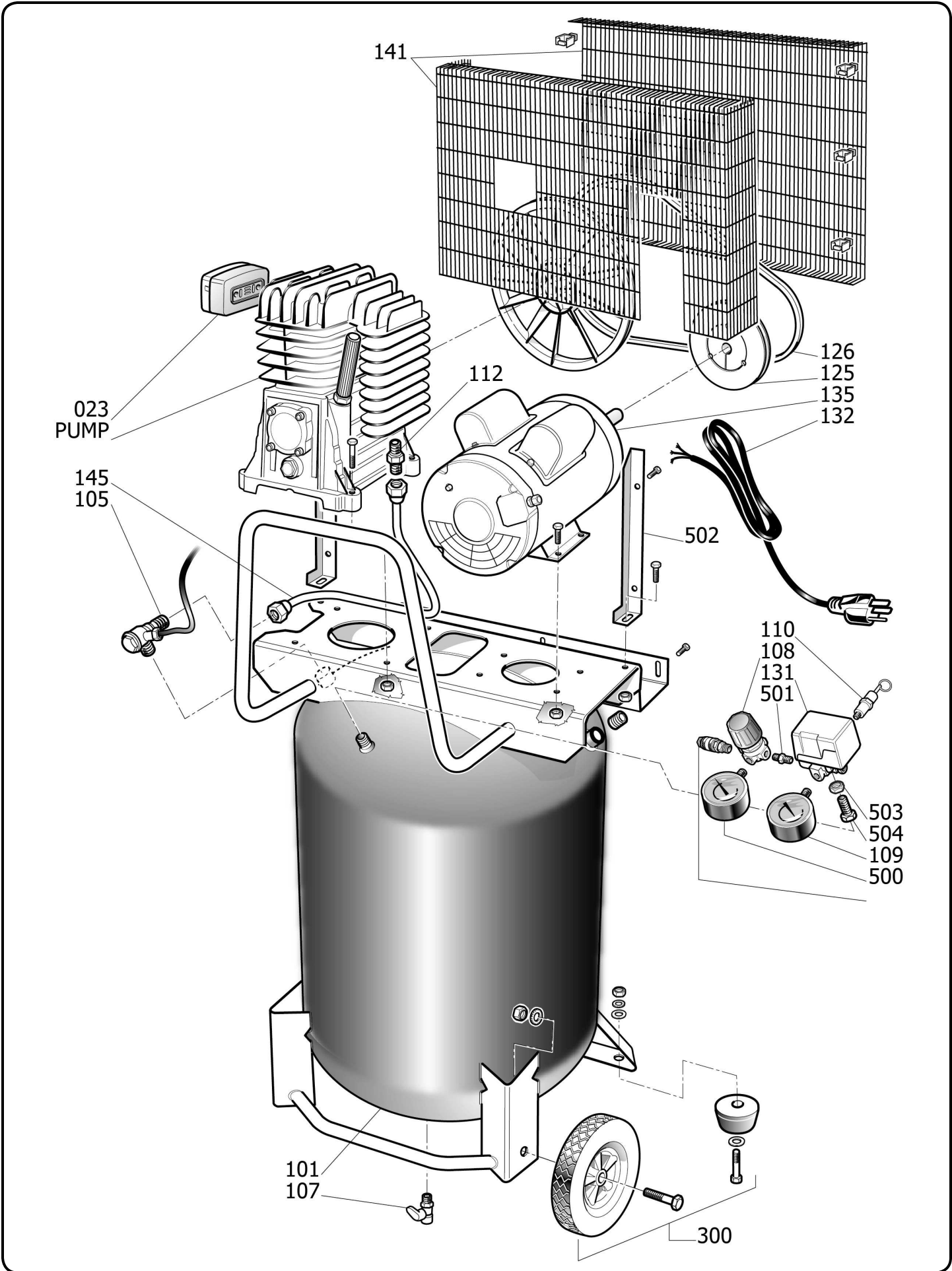

## PORTABLE AIR COMPRESSOR PARTS LIST- MODEL NO. 61489

The model number will be found on a plate attached to air tank. Always mention the model number in all correspondence regarding your **PORTABLE AIR COMPRESSOR** or when ordering replacement parts.

| KEY NO. | CODE              | DESCRIPTION                           | Q.TY |
|---------|-------------------|---------------------------------------|------|
| 023     | <b>2881000</b>    | AIR FILTER.....                       | 1    |
| 101     | <b>9413418021</b> | TANK 29 GAL .....                     | 1    |
| 105     | <b>9048003</b>    | CHECK VALVE .....                     | 1    |
| 106     | <b>9047061</b>    | QUICK COUPLING.....                   | 1    |
| 107     | <b>9047051</b>    | TAP BALL VALVE .....                  | 1    |
| 108     | <b>9051204</b>    | PRESSURE REGULATOR.....               | 1    |
| 109     | <b>9052130</b>    | GAUGE 2" 1/4 RAD CPI.....             | 1    |
| 110     | <b>9049115</b>    | SAFETY VALVE.....                     | 1    |
| 112     | <b>9053003</b>    | NIPPLE.....                           | 1    |
| 125     | <b>9076080</b>    | PULLEY 90 x 1A.....                   | 1    |
| 126     | <b>9075036</b>    | BELT .....                            | 1    |
| 131     | <b>9416728</b>    | PRESSURE SWITCH.....                  | 1    |
| 132     | <b>9065301</b>    | CORD WITH PLUG .....                  | 1    |
| 135     | <b>844F002</b>    | MOTOR HP2 M 120/60 .....              | 1    |
| 141     | <b>838000A</b>    | BELT GUARD .....                      | 1    |
| 145     | <b>9043348</b>    | SENDING PIPE .....                    | 1    |
| 300     | <b>9420719</b>    | KIT WHEELS .....                      | 1    |
| 500     | <b>9416774</b>    | GAUGE 2" 1/4 RAD CPI LONG.....        | 1    |
| 501     | <b>9414633</b>    | DOUBLE SCREW.....                     | 1    |
| 502     | <b>9083296</b>    | SUPPORT FOR BELT GUARD .....          | 1    |
| 503     | <b>9050375</b>    | CONNECTION 1/4" .....                 | 1    |
| 504     | <b>9050376</b>    | TURNING NUT 3/8" .....                | 1    |
| PUMP    | <b>2800070</b>    | PUMP B2800 WITH AFTERCOOLER 180°..... | 1    |

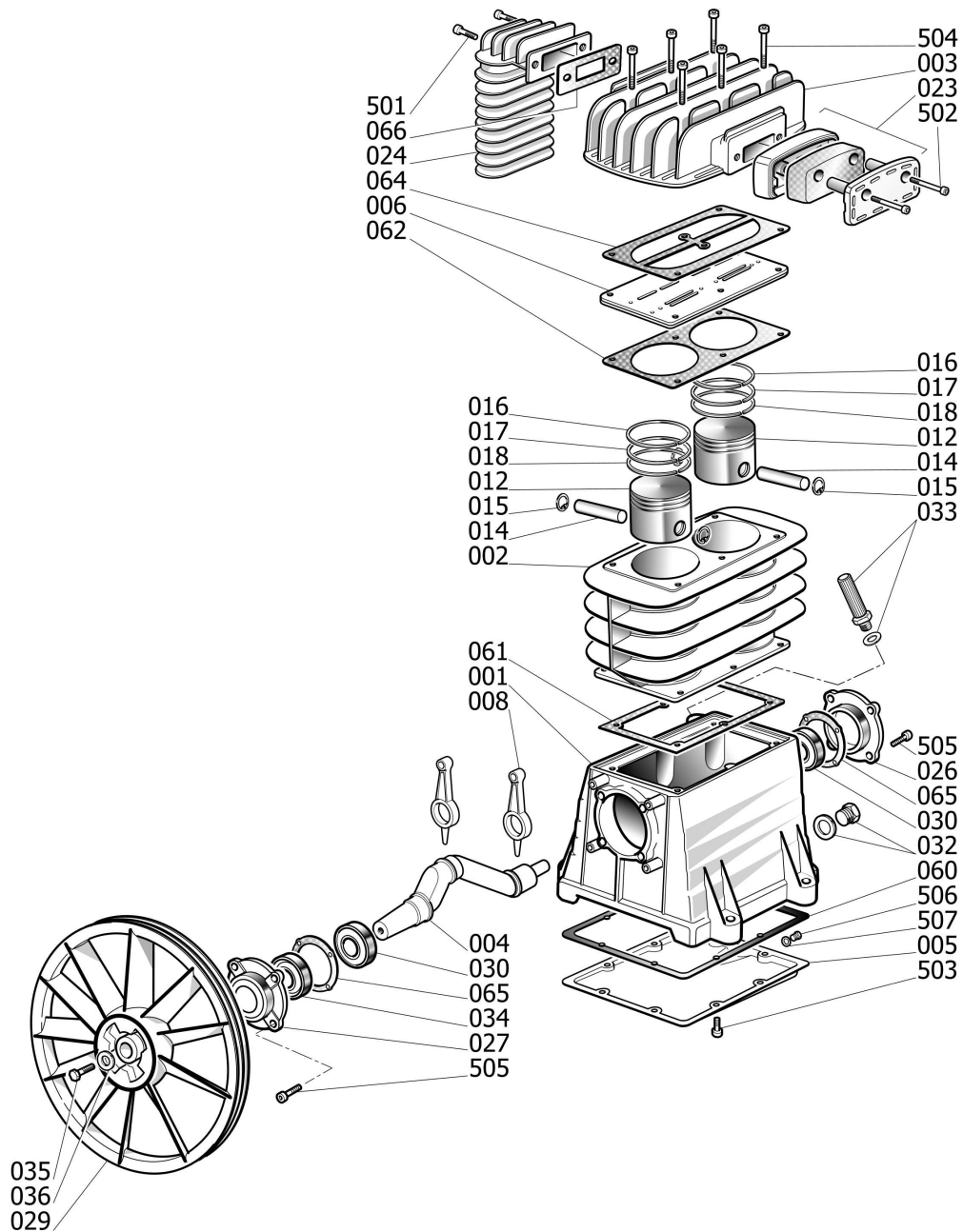

| KEY NO. | CODE    | DESCRIPTION           | Q.TY | KEY NO. | CODE    | DESCRIPTION                  | Q.TY |
|---------|---------|-----------------------|------|---------|---------|------------------------------|------|
| 001     | 2860101 | CRANKCASE.....        | 1    | 032     | 9022001 | OIL LEVEL.....               | 1    |
| 002     | 2830001 | CYLINDER.....         | 1    | 033     | 9024029 | BREATHER.....                | 1    |
| 003     | 3860400 | HEAD.....             | 1    | 034     | 9163010 | GASKET.....                  | 1    |
| 004     | 2860200 | CRANKSHAFT.....       | 1    | 035     | 9110014 | SCREW.....                   | 1    |
| 005     | 2660500 | CRANKCASE BOTTOM..... | 1    | 036     | 9004008 | WASHER.....                  | 1    |
| 006     | 2840050 | ASS.VALVE PLATE.....  | 1    | 060     | 2650101 | GASKET CRANKCASE.....        | 1    |
| 008     | 2810100 | CONROD.....           | 2    | 061     | 2850200 | GASKET CRANKCASE-CYLINDER..  | 1    |
| 012     | 1421100 | PISTON.....           | 2    | 062     | 2850300 | GASKET CYLINDER-VALVE PLATE. | 1    |
| 014     | 3021200 | PISTON PIN.....       | 2    | 064     | 2850400 | GASKET VALVE PLATE-HEAD..... | 1    |
| 015     | 9140040 | SNAP RING.....        | 4    | 065     | 2050500 | GASKET COVER.....            | 2    |
| 016     | 9020011 | SEAL AC.....          | 2    | 066     | 1070200 | GASKET AFTERCOOLER.....      | 1    |
| 017     | 9020041 | SEAL ROS.....         | 2    | 501     | 9101144 | SCREW.....                   | 2    |
| 018     | 9020071 | SEAL ROF.....         | 2    | 502     | 9415853 | SCREW.....                   | 2    |
| 023     | 2881000 | AIR FILTER.....       | 1    | 503     | 9411090 | SCREW.....                   | 12   |
| 024     | 2870100 | AFTERCOOLER.....      | 1    | 504     | 9101594 | SCREW.....                   | 6    |
| 026     | 2060690 | COVER LOV.....        | 1    | 505     | 9101094 | SCREW.....                   | 8    |
| 027     | 2060500 | COVER LV.....         | 1    | 506     | 9101034 | SCREW.....                   | 1    |
| 029     | 2600100 | FLYWHEEL.....         | 1    | 507     | 9162020 | WASHER.....                  | 1    |
| 030     | 9170030 | BEARING.....          | 2    |         |         |                              |      |

# Other ManualsLib Projects



[www.manualslib.com](http://www.manualslib.com)



[www.manualslib.de](http://www.manualslib.de)



[www.manualslib.es](http://www.manualslib.es)



[www.manualslib.fr](http://www.manualslib.fr)



[www.manualslib.nl](http://www.manualslib.nl)



[www.manualslib.mx](http://www.manualslib.mx)



[www.manualslib.tech](http://www.manualslib.tech) 30+ Languages