

Protohaven

Sandblaster

SkatblastUSA 1536 Champion Abrasive Blasting Cabinet

Tool Tutorial

The [Setup](#), [Operation](#), and [Cleanup](#) Checklists of this guide are what instructors use to ensure that you can use the equipment according to community expectations.

The sandblaster uses pressurized air to spray abrasive against your material inside a protective cabinet. This helps you to remove old coatings, surface corrosion and oxidation; prepare parts for painting or powder coating; or even etch patterns into your material.

Usage Highlights

[Sandblaster Clearance](#) or [Class Equivalent](#) Required Before Use

SAFETY	CARE	CLEANUP
<p>1. Wear appropriate PPE</p> <p>2. Ensure all doors are closed and properly latched before use</p> <p>3. Always disconnect air before working on blasting gun</p>	<p>1. Check abrasive level before use</p> <p>2. Do not point the gun at the window, gauntlets, or anything other than the item being abraded</p> <p>3. Submit a maintenance request when needed.</p>	<p>1. Sweep or vacuum up any dust or debris</p> <p>2. Gently wipe the interior of the window</p> <p>3. Allow the gauntlets to dry if they've become moist due to sweat</p>

Personal Protective Equipment

Face Masks & Cleaning Kits are required at all times during the Pandemic.

While using the Sandblaster, **safety goggles** and a **dust mask** are also required. A **respirator with replaceable cartridges, particle filter mask, or vapor mask** is recommended, but a nuisance dust mask is sufficient for shorter tasks.

Closed-toed shoes (preferably boots) are required in the workshop.

Disposable gloves, although not required, may be used inside the gauntlets that are permanently affixed to the sandblaster.

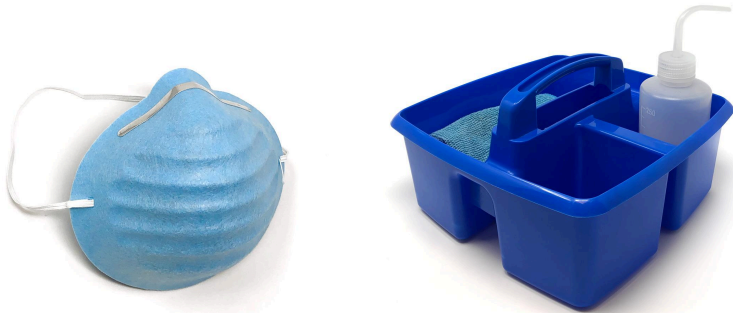

Tool Anatomy

MACHINE ANATOMY

1. **Power Switch** - on/off switch
2. **E-Stop** - Reserved for emergencies. To deactivate and reset, you must twist the spring-loaded knob.
3. **Maintenance Tag** - Manually tracks the usability status with Green/Yellow/Red cards
4. **Viewport** and **protective film** - allows the user to see what they're doing. The replaceable protective film helps preserve the viewport from abrasive damage.
5. **Access Doors** and **Latches** - allow access to the interior of the cabinet
6. **Siphon hose** - pulls media from the hopper to the gun
7. **Air Hose** - provides air pressure to the sandblaster
8. **Blasting gun** - directs the stream of abrasive
9. **Foot Pedal** - must be pressed for blasting to occur
10. **Screen Filter**- filters debris as material is removed
11. **Media hopper** - holds the abrasive media underneath the cabinet
12. **Trap Door** - Easy opening door for quick-access change of abrasive
13. **Gauntlet Gloves** - permanently affixed heavy gloves that allow the user to manipulate items inside the cabinet with the doors closed.
14. **Dust Collector** - keeps (most of) the dust generated by the sandblasting process from escaping into the vicinity of the sandblaster

Tool Safety

COMMON HAZARDS

DUST

The dust produced by the sandblaster is hazardous for your respiration

- Always ensure the access doors are properly latched before sandblasting
- Ensure your [PPE](#) is appropriate and properly rated for respiratory protection
- Always wear a respirator when adding/removing abrasive media
- Keep others safe by vacuuming any built-up dust on or around the cabinet—especially after changing out the media

ABRASIVE DAMAGE

Anything inside the cabinet can be damaged by the abrasive.

- Do not point the gun at the viewport
- Do not allow the abrasive blast to touch or abrade the gauntlets

PROHIBITED MATERIALS

WET, OILY, OR GRIMY MATERIALS

Wet or oily materials should not be used in the sandblaster, as it will cause the abrasive to gum up and become useless very quickly. The pool of abrasive can also be worn down with excess debris.

To avoid this, always remember to do the following before blasting:

- Ensure the material is clear of oil and moisture
- Remove dirt or any loose material from the surface by hand

RESILIENT MATERIALS

Resilient materials (e.g. items dipped in vinyl, or covered in soft paint or powder coat, etc.), while not prohibited, will not respond well to the abrasive flow, as the particles will tend to bounce off rather than remove the material.

It is strongly recommended that you remove as much of such materials as possible through chemical or manual means, then use the sandblaster to finish up removal in tight crevices and similar.

Initial Setup

SETUP CHECKLIST

1. **Check** the level of abrasive supply in the hopper.
2. **Ensure** that part(s) to be blasted are clean, dry, and oil-free.
3. **Unlock** latches on the door.
4. **Place** and [secure part\(s\)](#) inside.
5. **Close** the door and **Lock** the latches.
6. **Ensure** that the foot pedal is locked in the on position
7. **Begin** operation

CONSUMABLES

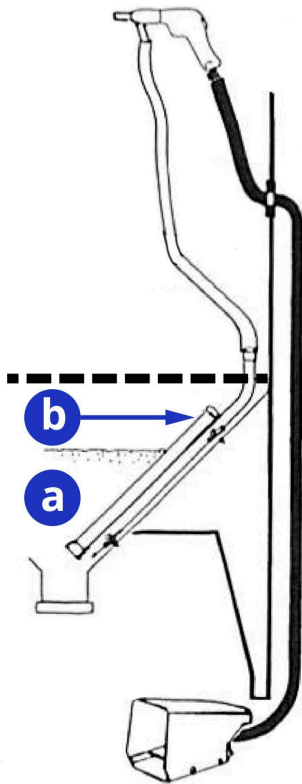

Keep (a) abrasive level below the (b) air inlet.

The level of abrasive in the hopper should be roughly $\frac{1}{3}$ of the total depth (between 25 and 50 pounds of abrasive).

If there is insufficient abrasive in the blast cabinet, or it does not appear to be abrading the material, please submit a [maintenance request](#).

Basic Operation

OPERATION CHECKLIST

1. **Turn on** the switch on top of the cabinet to turn on lights and start the vacuum.
2. **Put** your hands in the gauntlets.
3. **Aim** the gun and the part at about 45 degrees to one another, a couple inches away.
4. **Squeeze** the trigger to begin blasting.
5. **Move** the gun and part closer together or further apart to adjust the blast area.
6. **Sweep** the gun back and forth smoothly over the area to be blasted.

Before operation, always ensure both latches are firmly secured.



HOW IT WORKS

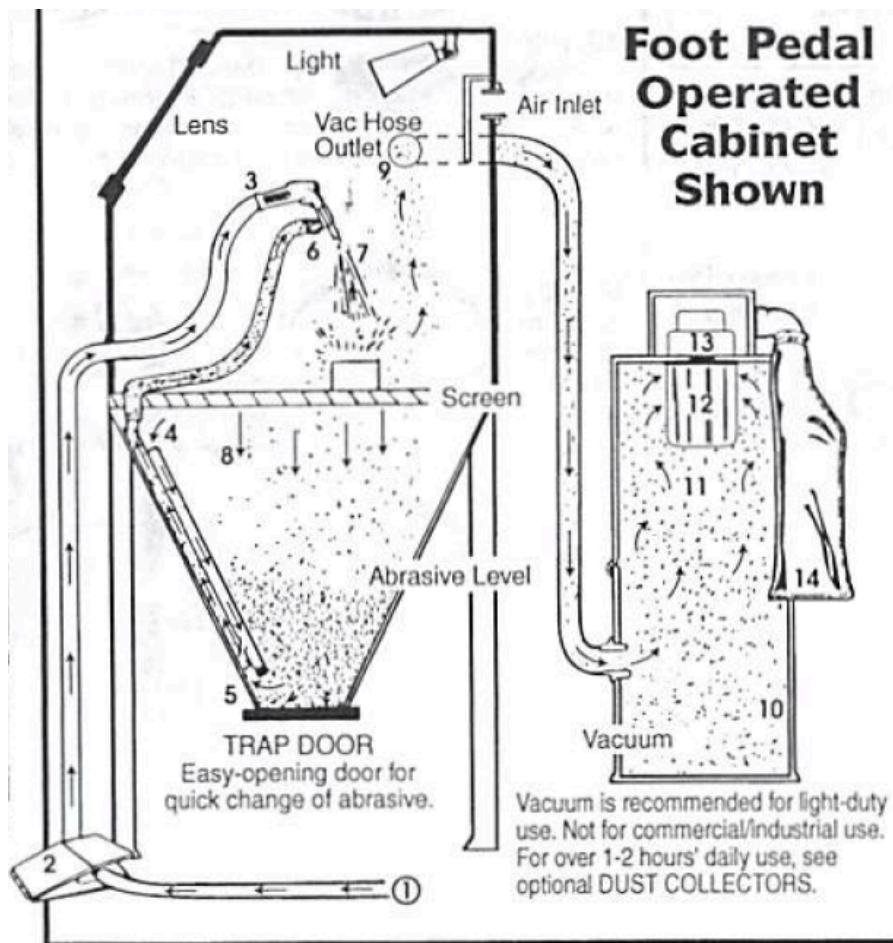

(1) Air from the compressor goes through (2) foot pedal control to (3) power gun. When pedal is pressed, air blows through the power gun, pulling makeup air into (4) pickup tube through (5) power zone, picking up abrasive through (6) gun venturi and out (7) nozzle.

Blast hits object. Most abrasive drops to (8) bottom for recycling. Dust is pulled out (9) vac hose outlet and into (10) vacuum container. (11) Lighter particles stick to (12) internal filter cartridge and clean air exhausts through (13) vac motor and into (14) optional Final Filter.

WORKHOLDING



L-brackets (as seen on left) can be used to support workpieces via clamps, magnets, or gravity.

Small parts can be contained inside the basket (as seen on right).

Small parts must be safely secured, lest they take wing and fly about the interior. Use of scrap wood, clamps, baskets, or strong magnets may be required; just be sure to use clean, dry, and oil-free materials such as metal or wood (which you don't mind having abraded).

Larger parts can be held in the gauntlet not holding the gun (so long as there is clearance to avoid affecting the gauntlet with the abrasive), or allowed to rest in the cabinet under their own weight.

BACK-PURGING



A rubber ball makes an ideal stop for back-purging.

Press the tip of the siphon gun directly against a piece of rubber or similar material.

Then, squeeze the trigger for a few seconds.

Cleanup

CLEANUP CHECKLIST

1. **Turn off** the switch on top of the cabinet.
2. **Sweep or vacuum up** any extraneous dust on or around the cabinet
3. If necessary, **wipe** the interior of the viewport with a dry cloth to improve visibility.
4. **Invert** (turn inside-out) the gauntlets, so that they can more easily dry out before the next user.
5. **Note** any maintenance needs or concerns on the tag and at protohaven.org/maintenance

MAINTENANCE REQUESTS

1. Update the physical Maintenance Tag at the machine
 - **Green** can be used without issue
 - **Yellow** can be used with caution
 - **Red** cannot be used without hazard to either the user or the equipment
2. Record issues at protohaven.org/maintenance. This notifies our staff and volunteer maintenance crew of any issues

Troubleshooting

Common Issues	Possible Causes	Resolutions
No abrasive coming out of the gun	Insufficient level of abrasive	Ask a volunteer to add more abrasive, so that the hopper is no more than $\frac{1}{3}$ full (roughly 25-50 pounds of abrasive)
	Abrasive not piled in hopper	Shake the hopper gently with your knee, to encourage the abrasive to settle.
	Siphon hose not in abrasive	Make sure that the siphon hose is in the abrasive hopper, and that there is enough abrasive to cover its lower end well
	Siphon hose clogged	Back-purge the gun and line, by pressing the tip directly against a piece of rubber or similar material, then squeezing the trigger for a few seconds.
Abrasive action seems poor	Bad angle or distance between gun and part	Experiment with different distances and angles between the gun and the part
	Material being removed is soft or resilient	Remove as much of it as possible outside the blaster, using chemical (e.g. paint stripper) or mechanical (e.g. wire brush, scrapers) means. Softer materials take longer to be blasted away.
	The abrasive may be worn down from use, or gummed up from inappropriately damp or oily material.	Please submit a maintenance request , in order to have the abrasive replaced.

Special Setups

RESISTS

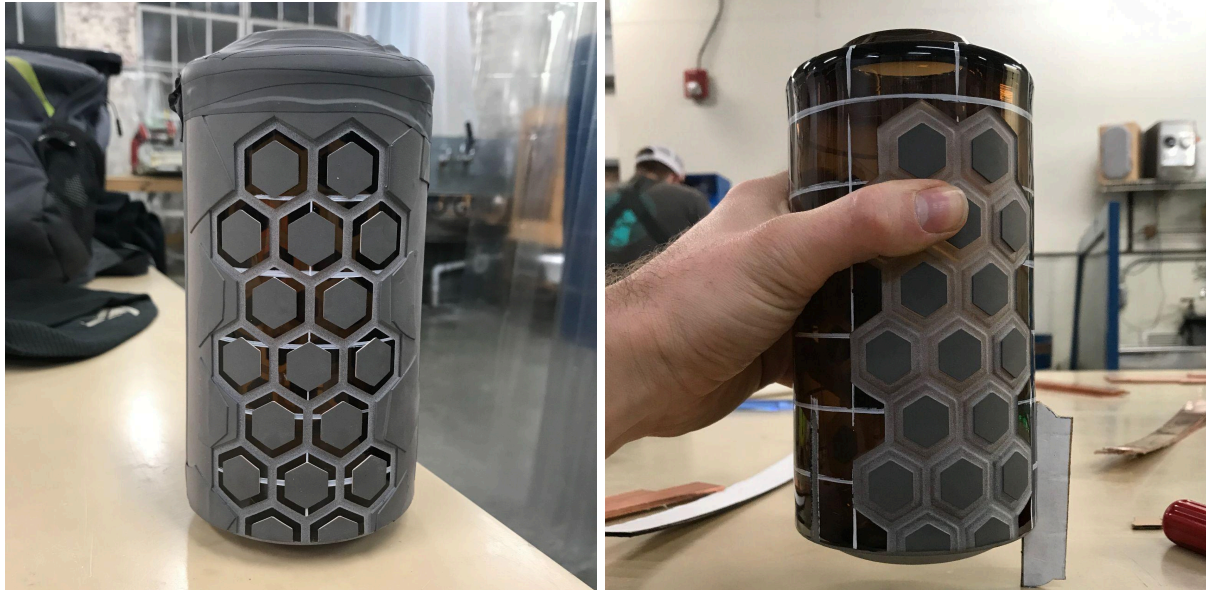

For etching materials such as glass, or protecting some portions of a part from being abraded, you may wish to use some form of resist...extra material used as a type of stencil to shield those surfaces you wish to protect.

Resists can be made of various materials...almost anything that is not easily abraded and can be securely fastened to the part will work.

For example, you could use the [Vinyl Cutter](#) to produce a resist that you could adhere to a glass bottle; after blasting the glass, peel the vinyl resist away, to reveal a clear pattern in the frosted glass.

OVERSIZED PARTS

If you wish to blast parts that are physically too long to fit into the cabinet with the doors closed, it is possible to construct a temporary extension out of materials such as duct tape and heavy cardboard, which you can fasten to the end of the cabinet with the door open.

Consult with a staff member before doing so, so that they can verify the safety, dust resistance, and structural integrity of the extension.

Additional Resources

[Manufacturer's website](#) and [FAQ](#)
[Skat Blast on Youtube](#)

SUPPLY RESOURCES

[Grimco Pittsburgh](#) (\$)
Local Vinyl Supplier

[Buttercut Resist](#) (\$\$\$)
Highly resilient, rubber sandblast masking used for creating stencils that can be sandblasted. Can be cut by hand or with a [Vinyl Cutter](#).

[Photo Resist Film](#) (\$\$\$)
An advanced photo-imageable film alternative to hand-cut and plotter-cut vinyl. Allows for a finer image quality without the hassle of weeding.

Staff-Use

AUTHORIZED MAINTENANCE CREW ONLY

If you are part of the maintenance group please log on to the #maintenance channel of our Discord server to:

- Perform a Maintenance Action
- Request a Maintenance Purchase
- Review complete Maintenance Logs for each machine
- Generally chit-chat about maintenance

Hippocratic Oath

- Start with the Manual
- Ask questions
- Do no harm
- Know your limits
- Document your actions

For more information:

[The Skat Blast FAQ](#)

[Sand Blast Cabinet Manual](#)

[Dust Collector Manual](#)